

OEM plastics technology

F I R S T C L A S S · B R A N D



BRAND

High End Technology

BRAND has a variety of technologies at its disposal for producing sophisticated and innovative plastic products.

Benefit from our years of experience in the processing of high-performance plastics.

We guarantee a consistently high level of performance for your project – starting with the development phase and on through design and production to assembly, packaging and logistics.

- BRAND develops and produces plastic products that create good value and loyal followers in their technology.
- Expert advice and project management – from concept to mass production
- Expertise in product development and mold-making
- Manufacture of high-performance plastics
- Production carried out in one of the largest and most modern clean rooms worldwide for plastic injection molding
- Highest quality standards



The latest technologies guarantee Highest Quality – batch after batch



BRAND carries out production in one of the largest clean rooms using the latest clean-room technology for plastic injection molding worldwide.

■ Approximately 3200 m² of validated clean-room floor-space, ISO class 8

■ Additional room-in-room systems for ISO Class 5 and 7 (DIN EN ISO 14644-1)

■ Total of 6000 m² of production area

BRAND only produces sophisticated plastic products that meet today's high demands under these optimum hygienic conditions.

From the beginning, with BRAND – your experienced partner

For decades, BRAND has been the expert when it comes to the innovative development and production of disposable and reusable high-performance plastic products.

With know-how, advanced production technology and high-quality awareness, BRAND is an outstanding partner for customized high-precision plastic components, assemblies and sterile disposable plastic items.

BRAND high purity products can be found in areas that demand a consistently high level of quality, such as:

- **Biotechnology, life science**
- **Research**
- **Semiconductor manufacturing**
- **Chemical and environmental engineering**
- **Medical technology, IVD**
- **Food and beverage industry**
- **Processing industry**
- **Optical industry**

BIO-CERT®
BIO-CERT®



From the initial idea through series production

BRAND offers expertise throughout each phase of your project

Development and Project Management

An experienced team of highly qualified specialists with years of experience in development, patent research, quality planning, plastics and production technology will work together closely on your project.

Your ideas, in collaboration with our development team form the basis for producing a high quality, economical and successful product.

We develop a production concept according to your wishes and requirements.

We work according to **DfX principles** right from the start during the project planning phase:

- **Design for Costs (DfC)**
- **Design for Manufacturing (DfM)**
- **Design for Reliability (DfR)**
- **Design for Quality (DfQ)**

Our development and design benefit from the latest state-of-the-art in type processing:

- **Production-integrated R & D**
- **Simultaneous Engineering**
- **Mold Flow Simulation**
- **FEM calculation**
- **Failure Mode and Effects Analysis (FMEA)**
- **Manufacturing Execution System (MES)**
- **Operation data acquisition (BDE)**
- **CAD / CAM**

Our goal is an economical production process that is as fully automated as possible and with the highest product quality.

Using near-series prototypes fabrication techniques or real parts from pre-series the product becomes more and more tangible for you throughout each stage of development.

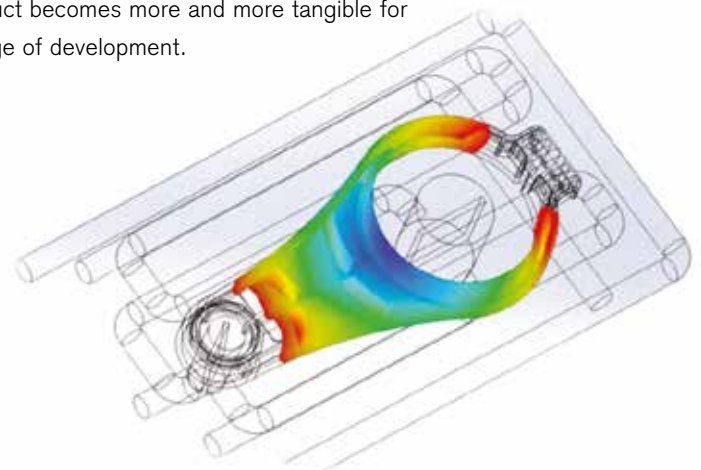

IP Management

As the project progresses, we conduct the necessary patent searches. Upon request, we can prepare the documentation for a patent application.

Mould Design

Manufacturing can only be carried out using durable and economical tools. We know what is important when designing the mould based on many years of experience in mass production.

Precise, high-performance injection moulds are created in cooperation with highly specialized and experienced moldmakers.



Special measuring cylinder class A

Water bottles

Wide neck storage bottle 500 ml or 1000 ml

Centrifuge tube with a stopper

Cell culture plates

Palletized dosing needles with matching box

Packaging for wafers

Cleanroom Manufacturing

We achieve a very high consistency in the environmental conditions through optimum control and continuous monitoring of all important clean room parameters. This ensures reliable, high quality production. These create ideal conditions for producing bio- or medical devices that are manufactured RNase-, endotoxin-, DNA- and ATP-free.

If required, all products can be supplied sterile in accordance with ISO 11 137 and AAMI guidelines.

Specially trained professionals in the clean room will oversee the production process.



Complementary Technologies

■ Surface modification

BRAND utilizes innovative techniques to produce products with functionalized surfaces such as:

- Irradiation
- Wet-chemical coating
- Plasma treatment

The surface energy can hereby change so that depending on the objective, specific surface properties can be adjusted. This is how, for example, plastic surfaces with hydrophobic or hydrophilic, cell-binding or cell-repellent properties, etc. are created.

■ Manufacturing Automation

Automation using industrial robots and flexible inline operations.

■ Modern parts handling

Efficient handling of parts by automatically unloading in buffer and depot systems

■ Laser Technology

Laser transmission welding and laser marking

Injection Molding

We produce, with more than 40 modern, mostly electric injection molding machines with clamping forces up to 200 t, high-precision plastic parts (with a part weight of 0.1 g to 500 g) under clean room conditions.

We routinely process:

- Standard plastics such as PP, PE, PC
- Fluoroplastics such as ETFE, PFA
- Technical polymers in optical quality, such as COC, PMMA, PS
- High-temperature plastics such as PEEK, PEI, LCP

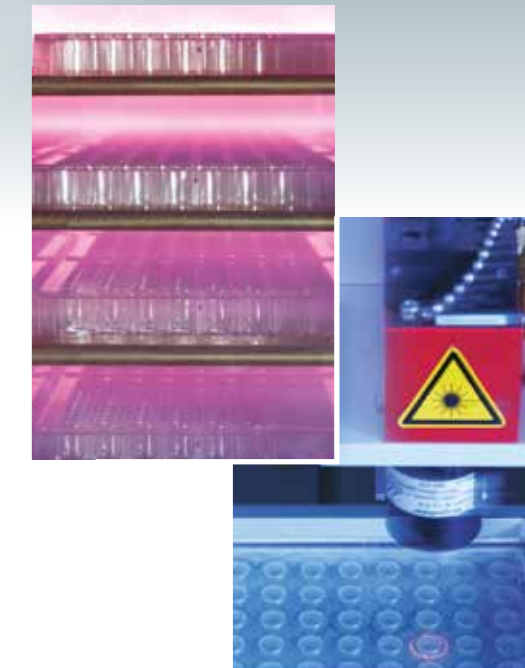

150:1 ml
Class A



Printing and Assembly

BRAND carries out printing operations using pad or screen printing. As an option, marking and labeling can also be applied using hot stamping or laser-marking processes. The plastic surface is prepared and activated for these processes using flame, plasma or corona treatment. Manually executed assembly work is carried out by specially trained professionals in the clean room and supported through the targeted use of assembly machines. Installation, testing and primary packaging work can also be done in an ISO class 8 clean room.

Packaging and Logistics

We customize packaging and labeling according to individual request. Item identification is carried out using bar codes, data matrix or customer-defined labeling. BRAND stands for deadline and quantity reliability and warehouse logistics customized to your needs.

Quality Management

Together with you, we will determine your requirements for the new product and ensure compliance with those requirements. Modern robotic technology and consistent integrated quality (in Process Control IPC) and approval-testing guarantee reliable high-quality standards. We focus on optical and tactile 3D coordinate measurement technology and 3D scanners. And, of course, we regularly maintain and calibrate

test equipment. The BRAND biolab also runs micro- and molecular-biological quality checks on injection-molded products several times a day and constantly monitors the air and surfaces in the clean room. We comply with national and international regulatory standards and upon request, provide traceability for the raw materials as part of change controls.



Certification

- DIN EN ISO 9001
- DIN EN ISO 14001
- DIN EN ISO 13485 in process
- DAkkS calibration laboratory according to ISO / IEC 17025
- cleanroom production according to ISO 14644 ISO class 5 to 8
- CE certification for products
- ISO 50001 energy management



Know-how through experience

For over 60 years.

The name BRAND signifies the highest quality in laboratories all over the world. This is true for our demanding line of liquid handling products as well as for our well-known BLAUBRAND® glass volumetric instruments, and our extensive range of disposable and reusable plastic products.

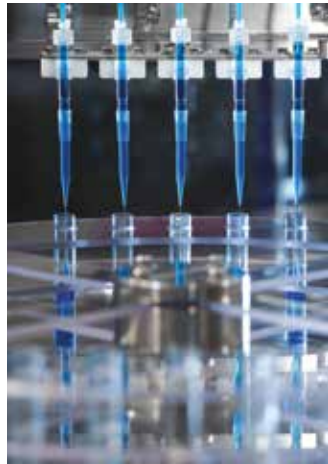

Quality is our business goal

From the design and selection of the best raw materials to the quality assurance systems in our own company, we strictly control each step along the way to the final product. With our dedicated staff and advanced production technology, we have everything necessary to offer our customers the highest product performance at an attractive price.

Dosing systems and equipment from BRAND

The experience accumulated during the development of our standard laboratory products provides a solid foundation for our dosing systems. This, together with our many years of experience in equipment and system design, makes us your expert partner, ready to offer solutions for your specific dosing requirements.

OEM plastic injection-molded products by BRAND

Our strength lies in our expertise in developing and manufacturing technically demanding plastic products characterized by outstanding optical properties and defined surface consistency. Mainly thermoplastic materials are used in production, under cleanroom conditions of class 8, 7 and 5 (ISO 14644-1) when required.

An interdisciplinary team of specialists develops custom solutions for specific requirements – from concept to development to the implementation of high-performance products.

BRAND®, seripettor® and BLAUBRAND® are trademarks of BRAND GMBH + CO KG, Germany.

Our technical literature is intended to inform and advise our customers. However, the validity of general empirical values, and of results obtained under test conditions, for specific applications depends on many factors beyond our control. Please appreciate, therefore, that no claims can be derived from our advice. The user is responsible for checking the appropriateness of the product for any particular application.

Subject to technical modification without notice. Errors excepted.

BRAND GMBH + CO KG · P.O. Box 11 55 · 97861 Wertheim · Germany
Phone: +49 9342 808-0 · Fax: +49 9342 808-98000 · E-Mail: info@brand.de · Internet: www.brand.de

